

SPECIFICATIONS

Power: 110V, 60 Hz

Consumption: 170W

Thermostat: Mechanical control

Cooling temperature: 41°F ~ 46°F

Tank capacity: 0.5 gallons

Cooling capacity: 3.4 gallons / hour

Dimensions : W x D x H (cm): 16 29/32" x 11 13/16" x 20 15/32"

Weight: 48.5 lbs

Water inlet diameter: 1/2"

Water outlet diameter: 1" female plastic flanged fitting

Power cord length: 71"

Material of body: Stainless steel panels (1/32" thickness)

Three finishes are available: 1) Stainless steel
2) Silver cream
3) Charcoal grey

Compressor:

Brand: Matsushita (Panasonic)

Capacity: 1810 Btu/h

Working: 250W

Power: 2.85A

Refrigerant: R134A

International Drinking Water Fountain's advantages

- Triple filtration system (Sediment, softener and charcoal filter)
- Water leak detector
- Stainless steel tank
- Conditional warranty of 7 years on cooling components and labour
- Must be installed with a leak detector (see the conditions of our warranty on our website)

DRINKING WATER FOUNTAIN

SO-295



Parts



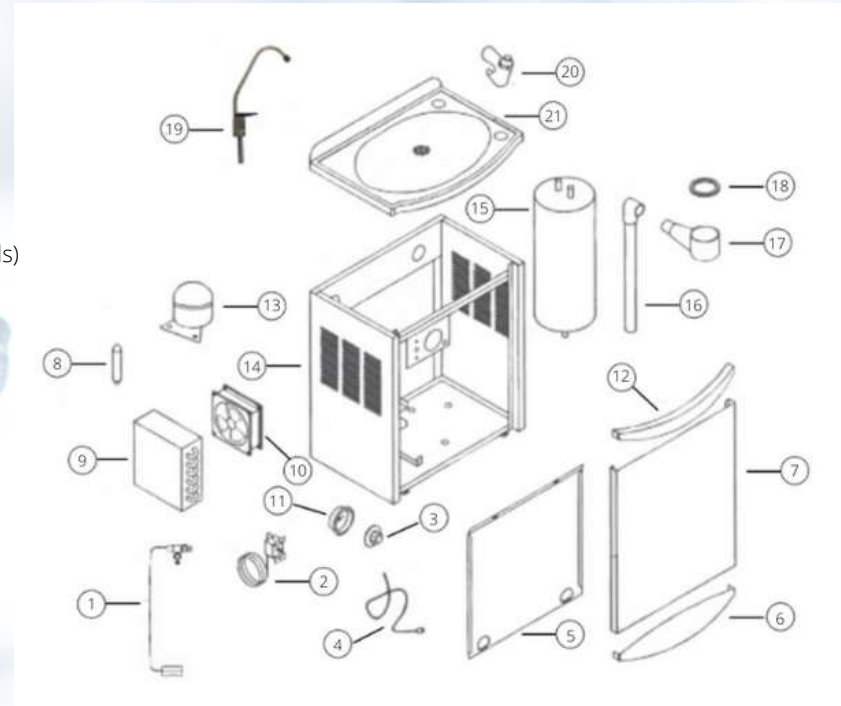

1. Water leak detector
2. Thermostat
3. Thermostat knob
4. Power cord
5. Bottom panel
6. Lower front panel piece
7. Front panel
8. Drier
9. Condensor
10. Cooling fan
11. Thermostat knob holder
12. Upper front panel part
13. Compressor
14. Frame (back, left and right panels)
15. Water tank
16. Drain tube
17. Drain cup
18. Drain cup rubber
19. Long reach faucet (optional)
20. Bubbler
21. Basin



DRINKING WATER FOUNTAIN

SO-295



1	Use the support to hang up the fountain. We recommend that the unit be installed at a height of 41 1/4". It is recommended to use a level. The top of the tank will therefore be at 41 3/4". Screw the support securely to the wall structure with 4 screws.	
2	Unscrew each of the screws that hold the front panel - at the bottom and on the sides	
3	Remove the filters, if necessary, while the appliance is being installed,. The filters are screwed and unscrewed in the opposite direction to the normal. So to screw them in, you have to turn them counterclockwise.	
4	Make the drain connection with a 1" male thread fitting and put at least 5 turns of Teflon into it. See the diagram on the next page for the distances.	
5	Screw in the supplied 3/8" Press fit fitting with 5 turns of Teflon. Push and remove the tubing 4 or 5 times to be sure it is fully seated in the bottom of the fitting. See diagram on the next page for distances.	
6	Fill in the installation date on the maintenance sheet.	

DRINKING WATER FOUNTAIN

SO-295



NOTE : Proportions are not exact but the measurements are

Position of the drain under the unit (A label indicates 'Drainage')

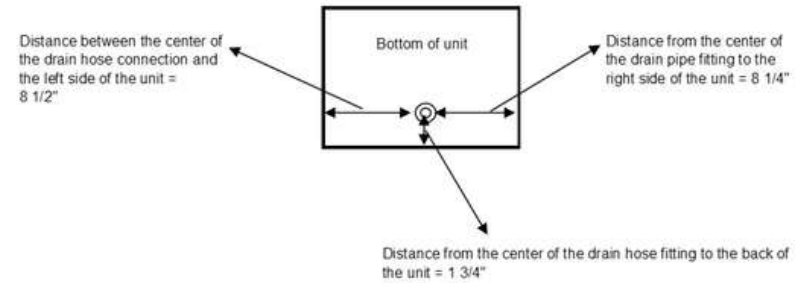

Position of the water inlet under the unit (A label indicates 'Water In')

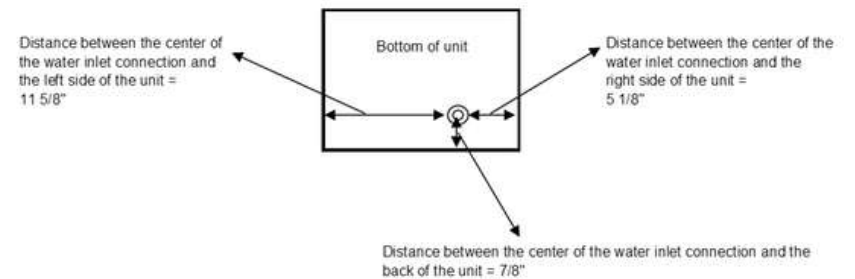

Distances suggested for installation of the unit

